

Jitter Filters Five Section Cavity



RLC Electronics' Jitter Filters are designed for use with jitter analysis systems. Modern digital networks may generate or transfer jitter. Excessive jitter can cause high bit error rates. Jitter filters are used to suppress the harmonic content of the

reference clock and recovered clock signals. Jitter Filters also suppress any sub-harmonics or other spurious signals that may be present. The 30 dB stopband extends to D.C. and to above the third harmonic.

Specifications

JF⁻¹

Model Number	Center Frequency (MHz) f_c	Loss at f_c	1 dB Bandwidth	20 dB Attenuation Bandwidth	30 dB Attenuation Bandwidth
JF	50 to 200	≤ 3.5 dB	$f_c \pm 0.8\%$	$f_c \pm 1.6\%$	$f_c \pm 2.4\%$
	201 to 18,000	≤ 3.0 dB	of f_c	of f_c	of f_c

Power Rating: 0.5 watts average
Impedance: 50 ohms
VSWR: 1.3:1 Over the specified 1 dB bandwidth
Connectors: SMA Females

Temperature: +10° to +45°C Operating
Environment: MIL-E-5400, Class 1A except operating temperature

To designate the filter desired use:

(1) Center Frequency (Jitter Frequency) in MHz.

Example: JF-500 is a Jitter filter with a center frequency of 500 MHz, The filter has a minimum 1 dB bandwidth of 496 to 504 MHz, with a return loss of ≥ 18 dB. Rejection will be a minimum of 20 dBa at 492 and 508 MHz and 30 dBa at 488 and 512 MHz.

Outline Drawing

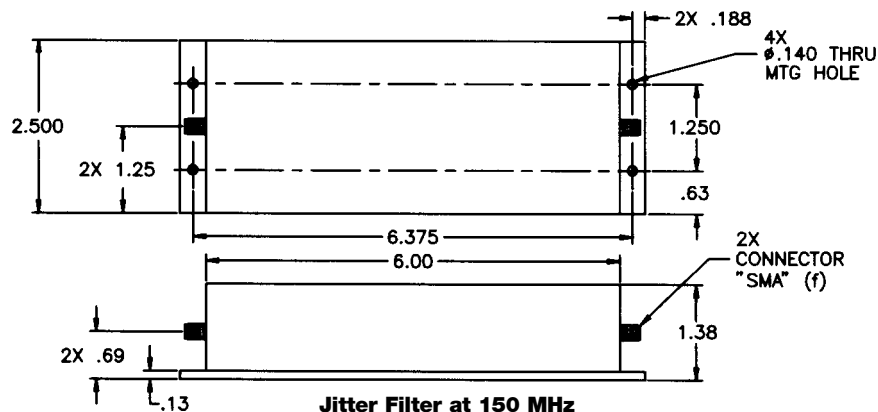
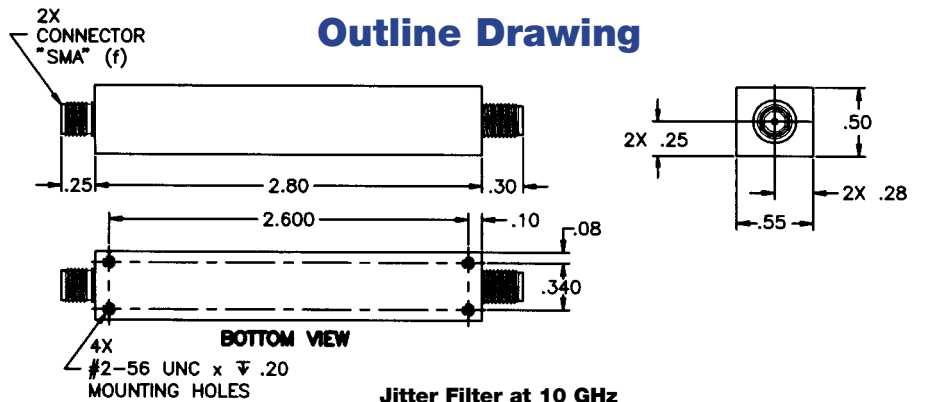

RLC ELECTRONICS, INC.

83 Radio Circle, Mount Kisco, New York 10549 • Telephone: 914-241-1334 • Fax: 914-241-1753
 e-mail: sales@rlcelectronics.com • www.rlcelectronics.com